



Seip
ANTRIEBS-TECHNIK
TS Akku II

Installation Instructions
for the garage door operator

TS Akku II

This booklet must be handed over to the end-user
together with the user-manual.



Content

Information and Remarks

Important Information for the Installer 3

- Directives and Regulations
- Use of the operators
- Garage Doors
- The installers declaration of conformity
- Older Garage Doors
- Instruction for the users

Security Advises for the Installation 4

Installation

Different Conditions for Installation 5

- Minimum space above the garage door
- C-Rail Extension
- Door Arm Extension

Pre-Mounting the operator 6

Installing the operator 6

- Minimum head room above the door

Adjusting the running-length blocks 8

The Emergency Release 9

- When the garage door is the only entrance
- When there is a second entrance to the garage

The Solar Components

Mounting the Shelf 10

Using and Recharging the batteries 10

- Usage
- Battery Status

Using and Recharging the Batteries 11

- Recharging the battery with the charger
- Duration of the recharging process
- Possible errors during the recharging process

Printed Circuit Board: Adjustments and Connections

Before Usage: Connecting the Battery Cable 12

Devices for Adjustments 12

- TEST-Button (1)
- LEARN-Button (2)
- Combined TEST + LERN button functions

Programming Running-Length and Force 13

- Information
- 1.) Adjusting the running-length blocks
- 2.) Starting the programming-mode
- 3.) Start the learning-cycle
- Quick Reference

Special Functions 14

- Readjusting the time for the internal light
- Setting the pre-warning ON/OFF
- Programming the Soft-Modes
- The BOTTOM Soft-Stop
- Programming the BOTTOM Soft-Mode
- Disabling the TOP Soft-Modes

External Connections 16

- Push Button and Key Switch
- 12V DC Supply
- Receiver-Module

Advanced Connections 16

- Photocell without self-test
- Photocell with self-test
- Safety-Beam, Hatch-Door and Emergency Stop
- Opto Sensoric Components

DIP-Switches 17

- TOP Soft-Mode enabled/disabled
- Force during the last 500mm before reaching closing limit
- Side Hinged Door

Remote Control

Programming the Hand Transmitters 18

- Basics
- Programming Transmitter and Receiver
- Clearing the receivers' memory

Additional Information 19

- Using the remote-control
- Criteria influencing the range
- Use with a HomeLink© System

Technical Information

Technical Data 20

Wiring 20

Messages from LED-lamps and operators lighting 21

- Status Messages
- Error Messages
- Messages from the red LED-lamp and the operators lighting

Important Information for the Installer

It is within legal regulation and without restriction, to use a Seip door operator with any garage door that has been approved for use with other certified door operators!

Directives and Regulations

The garage door operator TS Solar/TS Akku complies to the latest European directives and regulations. The declaration of conformity is enclosed at the end of these instructions.

Use of the operators

The operators were designed for the use with up-and-over doors (tilting and canopy-type) and sectional doors.

All garage doors need to be maintained before automation. The door must be easily opened and closed by hand. A garage door must not be automated unless it is easy to open and close manually.

Garage Doors

In January 2001 the European regulations EN12604 and EN12605 became compulsory for garage doors. Before installing an automatic door operator it must be assured that the garage doors applies to these regulations (the information can be obtained from the manufacturers' declaration of conformity). A Seip door operator may be installed to any door that complies to the regulations. Should a garage door not be compliant then please refer to the chapter „older garage doors“.

The installers declaration of conformity

No matter whether a door operator was delivered together with a garage door or separately, the installer must issue a declaration of conformity for the complete installation.

With this declaration the installer assures, that the installation was made according to the instructions given by the manufacturers (e.g. the installation instructions of the garage door and the operator). This declaration can only be issued by the installer and may not be issued from the manufacturer!

If both components comply to the directives and the installation was made as to the manufacturers instructions the whole installation will normally be CE-compliant.

Older Garage Doors

When automating an older garage-door the TS-series will still comply to the regulations - through the automatic force setting the requested values for forces and reversion will be according to the regulations.

But it needs to be taken in consideration that most older garage doors do not meet the regulations EN 12604 and EN 12605 - especially regarding security features. They might still have sharp edges bearing the danger of severe injuries - for example sectional doors might not have a finger protection between the sections. Unfortunately the entire regulations do not mention how to handle the automation of such an older garage door - the danger basically is not the automation but the construction of the door.

Therefore we strongly recommend to

- check the garage door for sharp edges bearing danger when the door is moving; take any necessary action to avoid the dangers and make the door safer
- check the doors' springs and readjust them if necessary
- grease or oil the pivotal points and rollers of the garage door
- check that the door may be easily used by hand



If, however, the dangers cannot be avoided we recommend to use the automatic pre-warning function of the operator. The operators' lighting will then be blinking for approx. 5 sec. before every movement of the garage door. People inside the garage will be warned before the opening and can step back from the garage door in time.

Instruction for the users

Please instruct the users as follows:

- Use of the hand transmitter
- Use of the emergency release in case of a power failure
- Hand over the separate „User Manual“ to the customer
- Inform the user about the Security Advises in the User Manual

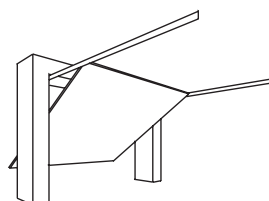

Up-and-over door

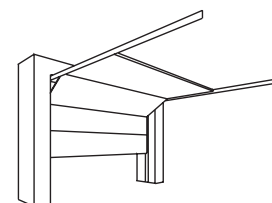

sectional door

Security Advises for the Installation

Important Safety Instructions for Installation

WARNING: INCORRECT INSTALLATION CAN LEAD TO SEVERE INJURY

Follow all Installation Instructions.

- Read page 3 of this instruction carefully before the installation
- Before installing the drive, remove unnecessary ropes from the existing installation
- Maintain the garage door according to the advises on page 3 and to the door manufacturer's manual
- If possible, install the drive at a height of at least 2,10 m and the manual release at a height less than 1,80 m
- Locate the push-button within sight of the door but away from moving parts and at a minimum height of 1,50 m
- Fix the label warning against entrapment next to the push-button
- The label fixed to the manual release may not be removed
- After installation, ensure that the mechanism is properly adjusted and that the drive reverses when the door contacts a 40 mm high object placed on the floor.

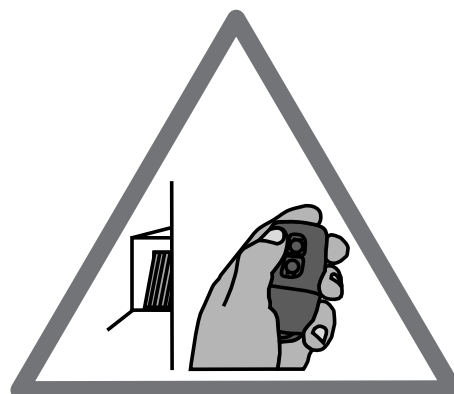

Different Conditions for Installation

Minimum space above the garage door

35mm Minimum

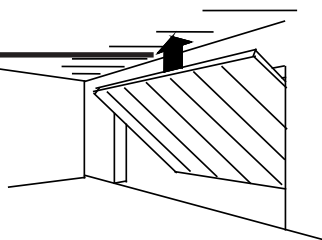

Before installing the operator you should check the garage for the conditions of installation. You will need optional extras in either of the following situations:

C-Rail Extension

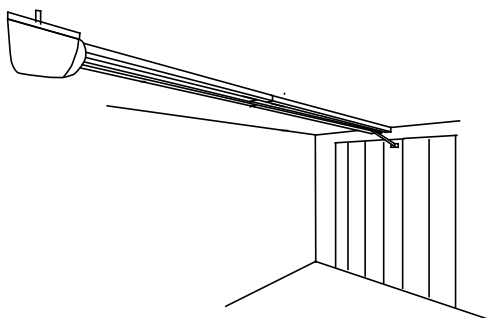

If the garage door is higher than 2.250 mm you will need a c-rail extension. Two sizes of extensions are available: 500mm and 1.000 mm.

The operator may be extended by a maximum of 1.500mm - the maximum height of a garage door is 4.150mm.

Door Arm Extension

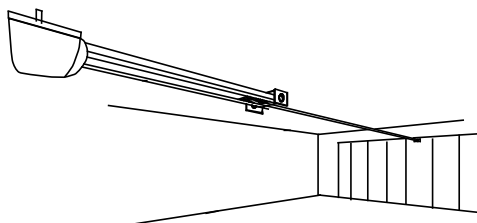

Should the minimum space between the garage door and the ceiling be smaller than 35mm then a door arm extension is needed. For an extension you can use a metal beam from any DIY-market. The beam should not be shorter than the door's height.

Pre-Mounting the operator

During this procedure be careful not to twist the chain. **Therefore do not lift the parts - slide them along the floor.**

1. The operator is laying unpacked in front of you. The motor-head unit is on your right hand side.
2. Lay part (1) to the front.
3. Fix through pushing the C-profile coupling piece (2) over it all the way home.
4. Slide C-rail part (3) in front of part (1)
5. Set part (3) in the C-rail coupling piece (4) at an angle, inserting it from above as shown.
6. Press down part (3) to tension the chain.
7. Turn around the operator and screw in the milled nuts into the C-rail coupling pieces.

Your operator now is readily premounted for installation.

The chain has been pretensioned in the factory; **do not change the chain tension!**

ATTENTION:

The TS Solar/TS Akku is equipped with a fully automatic measurement for the required running length. When shipped the operator is programmed with a standard running length for factory testings.

If you want to run the operator for testing purposes you must fix the blocks inside the c-rail by tightening the screws. **A test run may only be done after making sure, that the blocks are fixed properly. Otherwise damaged might apply to the operator!**

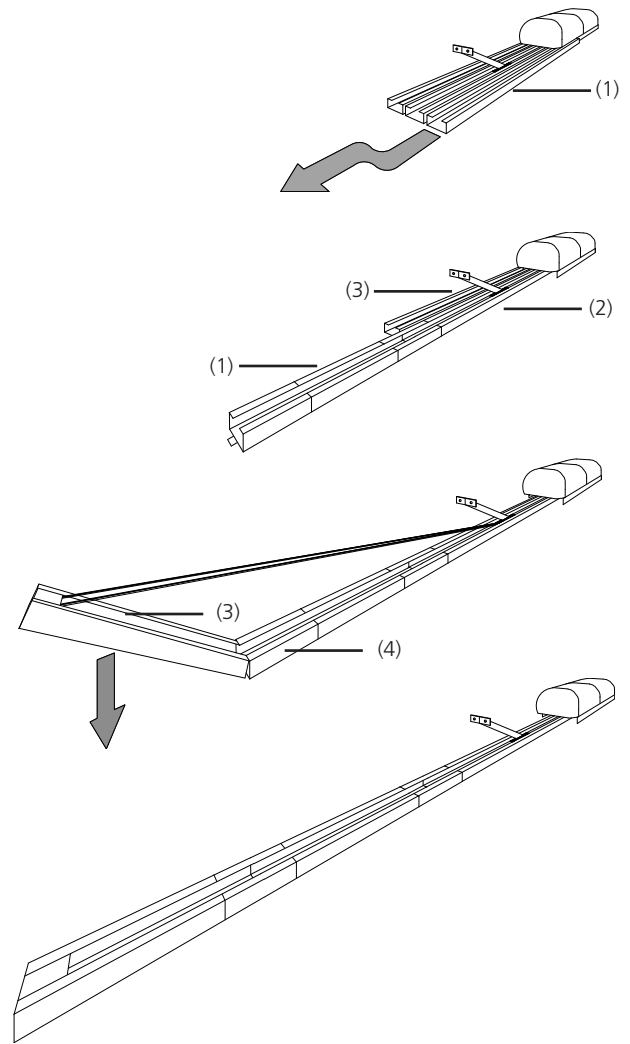

Installing the operator

Minimum head room above the door

Measure the distance between the ceiling and the highest point reached by the garage door (1).

The minimum-headroom necessary for mounting the operator is 35 mm. If there is less headroom please pay attention to page 5.

The front fixing angle can be mounted either at the lintel or at the ceiling.

1. Measure the middle of your garage door and make a mark on the lintel and the top of your door (2+2a).
2. Fix the front fixing angle in the middle either at the lintel or at the ceiling. (We recommend the lintel if possible) (2+2a).

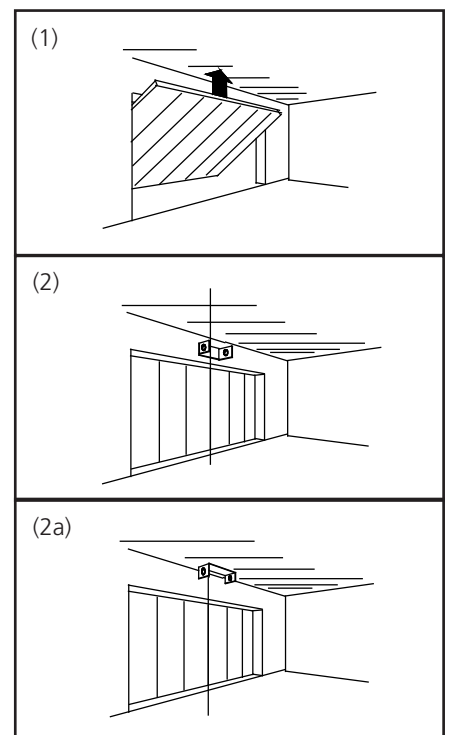

Installing the operator

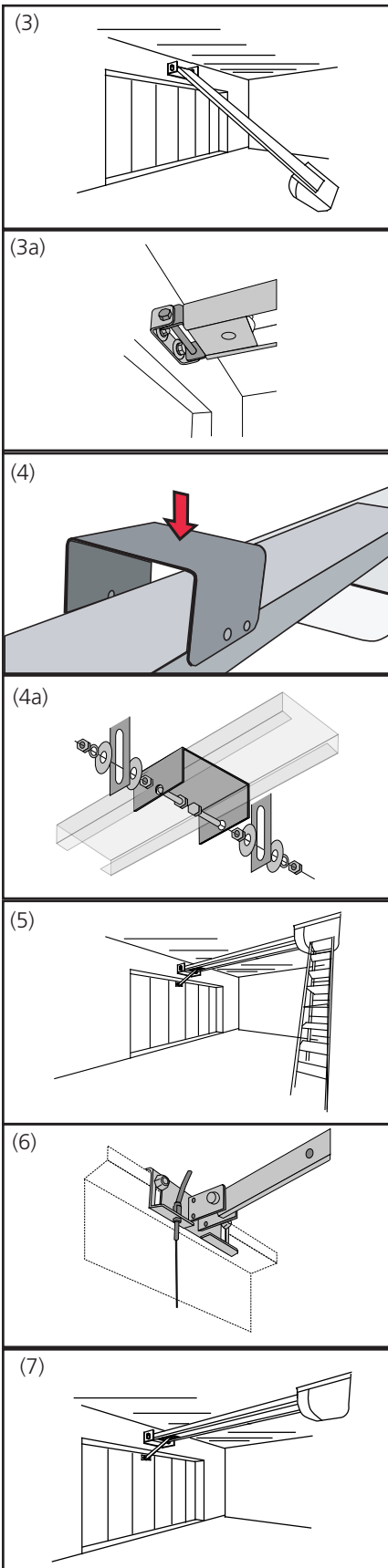

3. Attach the C-rail to the front fixing angle (3). Put a carton piece under the motor head unit to avoid damages.

4. To fix the motor head to the ceiling we recommend you to use a ladder (4). When the operator is laying on the ladder you can open the garage-door. Adjust the C-rail according to the mark you made in the middle of the garage-door.

Fix the operator to the ceiling when you have made sure the C-rail is running straight to the front. Use the supplied bracket to fix the C-rail to the ceiling (pic. 4 and 4a).

5. Now fix the door arm to the garage door (6). Take care that the angle between the operator and the door arm does not exceed a max. of 45° (it may be lower).

6. The limit-blocks must be tightened before running the operator!

The garage doors' bolts must be removed before running the operators - otherwise damages on the garage door or operator might occur!

For additional security our locking set can be obtained as an optional extra.

Adjusting the running-length blocks

These adjustments **must** be made **before the programming of the forces and the running-length.**

Starting the programming procedure without correctly adjusted blocks may lead to damages on the garage door and the operator!

Vorgehensweise:

1. The operator is mounted and the door-arm is fixed to the garage-door. The trolley is locked to the chain and stands somewhere between the two blocks. If, however, trolley and chain need to be moved you may do this using the TEST/RUN button.

2. Release the trolley (Pic. 1) and manually close the garage door.

3. The block for the closing direction is now right in front of the trolley (Pic. 2). If not, the block must be moved until it touches the trolley.

4. Tighten the blocks' screw to keep it in place. Take care not to tighten it too strongly - the c-rail should not be bended.

5. Now the garage door needs to be opened manually. The trolley will lock into the chain - you have to release it once again to fully open the garage door. (Pic. 1).

6. The block for the opening direction is now right in front of the trolley (Pic. 3). If not, the block must be moved until it touches the trolley.

7. Tighten the blocks' screw to keep it in place. Take care not to tighten it too strongly - the c-rail should not be bended.

8. The trolley now needs to be locked back to the chain!

After that the programming procedure may be started (page 12 onwards).

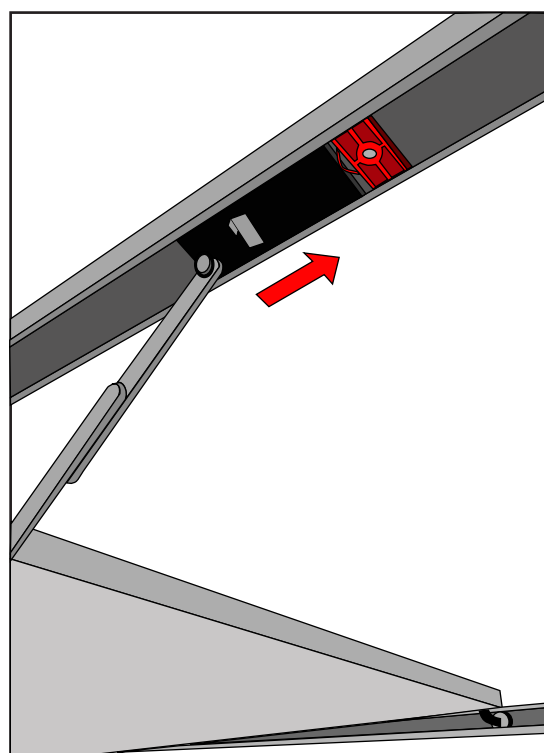
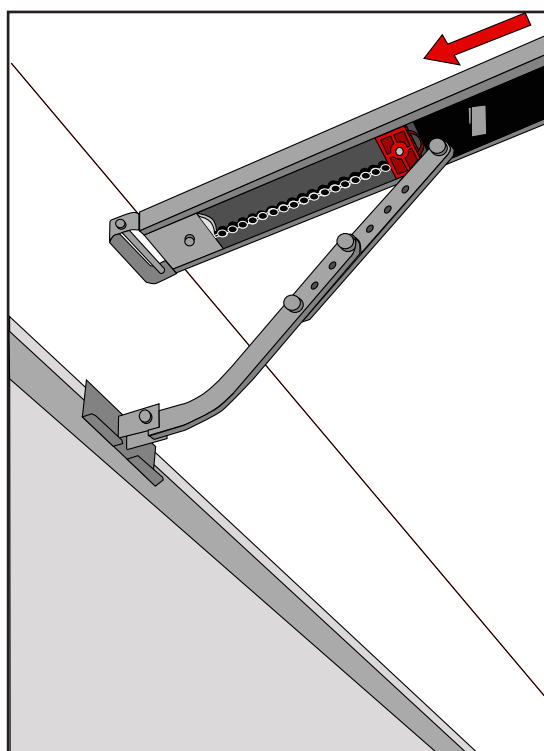
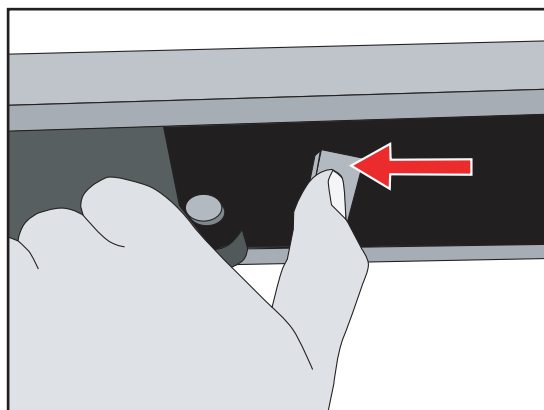

The Emergency Release

Pic. 1

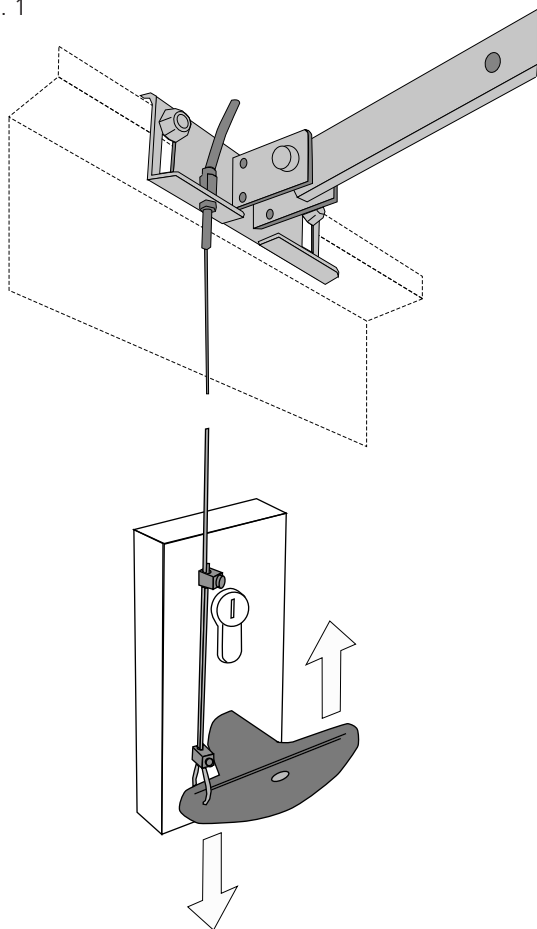

In case of a power failure the garage door can be opened by hand. Therefore the operator first needs to be released.

When the garage door is the only entrance

It is necessary to connect the emergency release to the door's handle (pic. 1) otherwise the garage cannot be accessed in a power failure situation.

Proceed as follows:

1. Find out in which direction the door handle moves when opening the door.
2. Drill a hole in that side of the door handle which turns downwards.
3. Thread the cable through the hole and fix it with the enclosed metal-clamps. Be careful not to put a high tension on the emergency release cable - the operator then might release from the garage-door during a normal opening cycle.
4. Check the function of the emergency release together with a second person. Stay inside the garage and close the door with the operator. Let the second person open the door manually with the door keys. If this works, the emergency-release is mounted properly.

Do not leave the garage and close the garage-door with the operator before you have tested the emergency-release!

Pic. 2

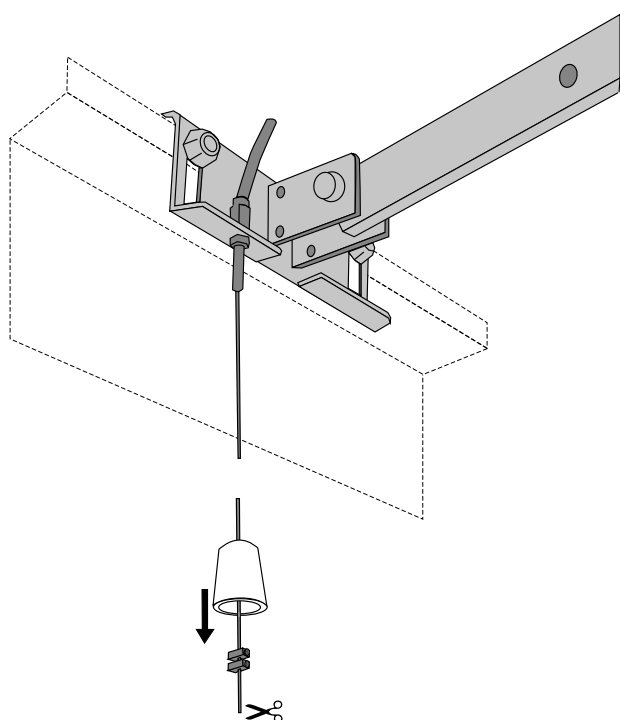

When there is a second entrance to the garage

You can use the supplied handle for the emergency release (pic. 2).

Thread the emergency release cable through the handle.

Fix the metal clamps to the cable where the handle shall be placed.

Shorten the cable below the metal clamps - the handle is now being held by the clamps.

In case of a power failure the user can now open the garage door by releasing the operator with the handle for the emergency release.

Mounting the Shelf

The shelf can take two batteries and is equipped with a 5m cable to supply the operator with power. Take care to install the shelf within the range of the 5m cable.

Mount the shelf to the wall using the supplied screws, then run the cable up to the operators.

Should the distance between the shelf and the operator be less than 5m, then the excess cable may be wound up - **the polarized plug must not be removed from the cable!** The cable must be run into the operator using the hole in the base plate. The cable can be kept in place using the supplied black detensioner.

The power supply cable must be connected to the operators electronics and a battery must be connected to the shelves' plug before the operator can be used (refer to page 12).

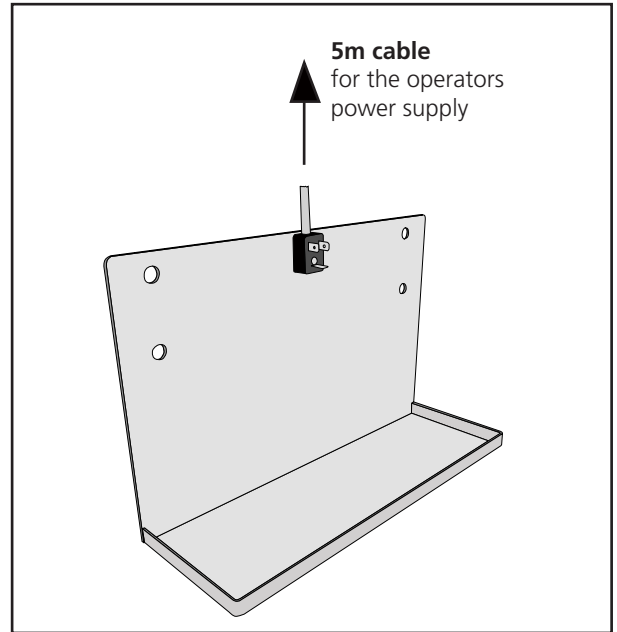

Using and Recharging the batteries

Hint: from factory-side the batteries are shipped fully charged

Usage

The shelf will take two batteries. The batteries may be used one after the other - whilst one supplies the operator with power, the other may be recharged by means of the supplied charger. After the battery was fully recharged, it remains beside the active battery, in order to overtake the operators supply once the first battery is running low.

The batteries are equipped with handles, allowing easy transport.

Battery Status

The battery status can be seen from the green LED, which can be found on the operators housing (please refer to page 21). The green LED will blink in turns of 10 seconds:
 - three times or twice: the battery is full
 - once: the battery is likely to run flat and should be recharged soon.

Shortly before the battery runs flat, **the operators lighting will start blinking whilst the operator is running.** Once this happens, the batteries power will only last for one or two mor openings (dependant on the doors weight). Here at latest the fully recharged battery must be plugged into the shelves' plug, whilst the old battery is taken into the house for recharging it.

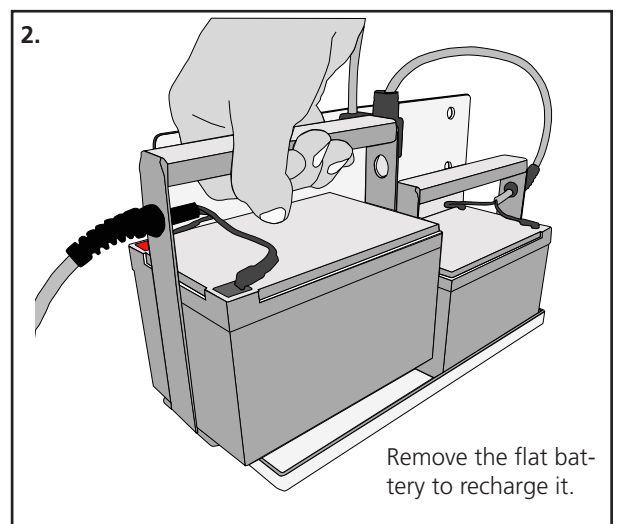
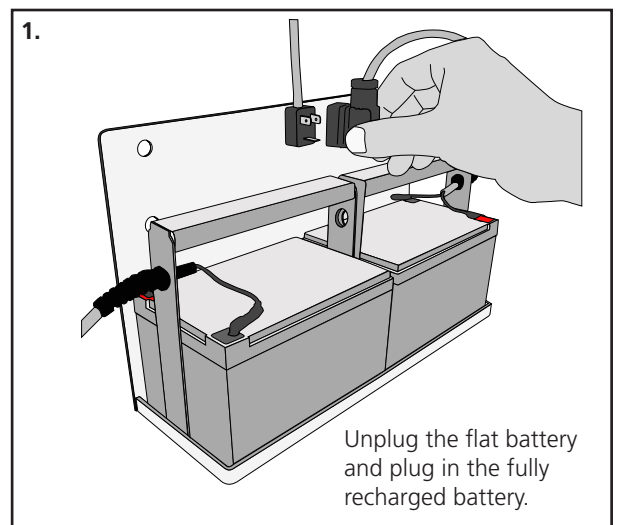

Using and Recharging the Batteries

3.

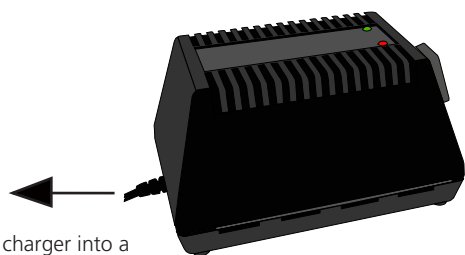

Plug the charger into a 230V power supply plug.

4.

The green LED goes on and indicates the charger is ready.



5.

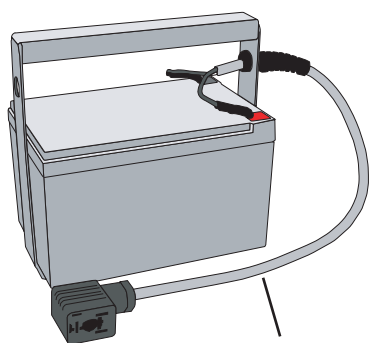

Cable for recharging the battery

6.

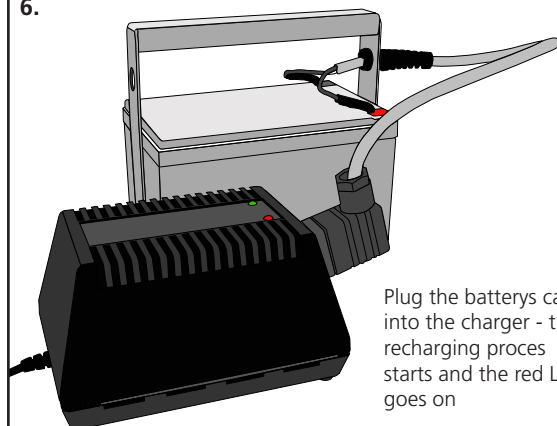

Plug the battery's cable into the charger - the recharging process starts and the red LED goes on

Attention: For recharging the batteries ONLY the supplied charger must be used - for damages on the batteries caused by usage of an incorrect charger no guarantee can be claimed.

Recharging the battery with the charger

- Take the flat battery out of the shelf and take it into the house for recharging it (pic. 2).

- Plug the charger into a standard 230V wall plug (pic. 3)

- The green LED on the charger starts glowing and therefore indicates it is ready for charging the battery (pic. 4)

- Place the battery (pic 5)

- Plug the battery's cable into the plug on the charger (pic. 6)

Now the recharging process starts. The red LED on the charger starts glowing, which indicates, that the battery is being recharged. The recharging process was completed when the red LED stops glowing - at that point unplug the charger from the 230V power supply. The battery can then be put back on the shelf where it stays as a spare until the other battery runs flat.

Duration of the recharging process

The time for recharging the battery depends on the status of the battery. Usually it will be sufficient to leave the battery connected to the charger over night. The charger is equipped with an automatic cut off, to prevent the battery from being overloaded.

Possible errors during the recharging process

The green LED does not glow:

Either a short-cut was created or the poles were swapped (with the standard polarized plug this should not happen)

The red LED does not glow when the flat battery is being connected:

- the battery might be damaged (a battery which had been stored flat for a longer time might get damaged and can hardly be recharged)

- Swapped Poles (this is only possible when changes were made to the original battery, e.g. the standard cable was removed)

- Check the connection (maybe the contacts or plug is a bit oxidated and therefore does not give a good contact)

The red LED does not stop glowing:

- Short-cut inside the battery or on the cables

- The battery cannot reach the maximum value of 13.8V - this might happen with older batteries. However, the battery might still be used with the operator but needs to be recharged more often.

Please also pay attention to the charger's instructions.

Before Usage: Connecting the Battery Cable

Before using the TS-Solar/TS-Akku the battery needs to be connected to the P.C.B.!

The red and black battery cables are equipped with a polarized plug which needs to be plugged onto the electronics connector „Bat. 12V“.

Information: red cable (+)-Pol, black cable (-)-Pol

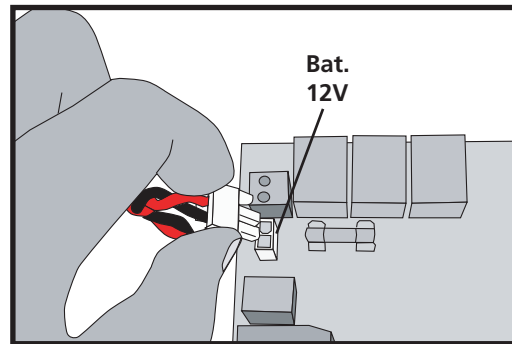

Devices for Adjustments

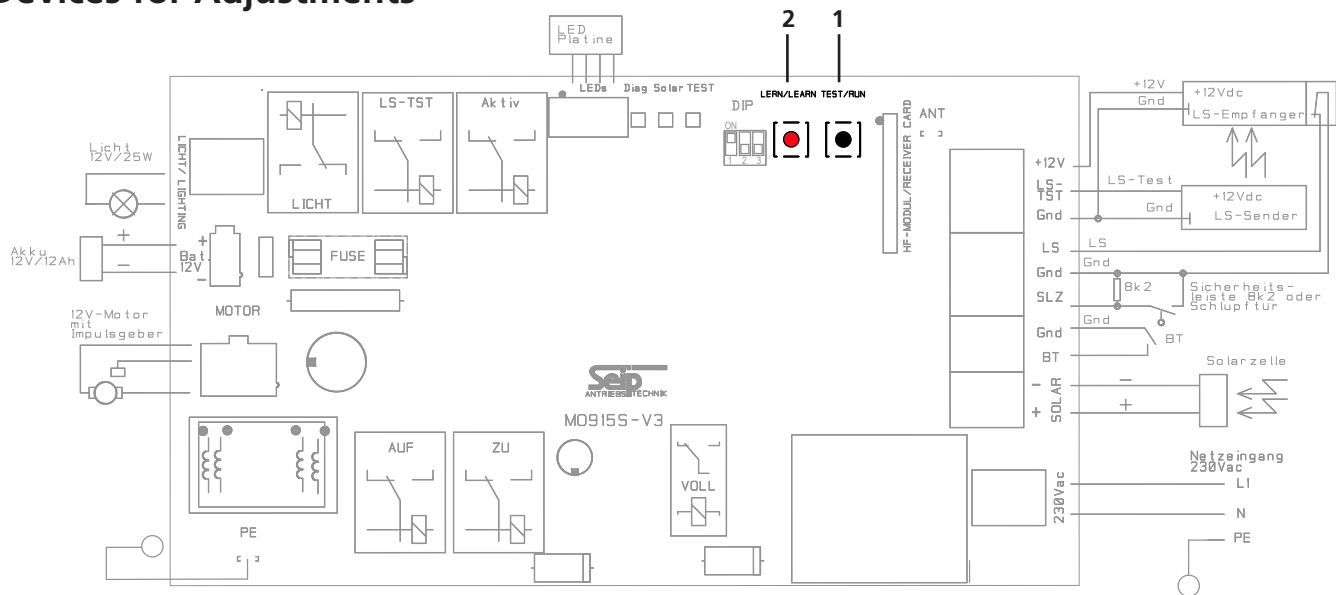

This page only shows the functions of the buttons and potentiometers on the P.C.B.. To programme the operator please refer to page 13 onwards.

TEST-Button (1)

With this button you put the operator into operation. The button works on the OPEN-STOP-CLOSE principle, e.g. the first push opens the door, the second push stops the door and the third push closes the door etc.

The green LED-lamp "TEST" is switched on as long as you press the TEST-button and shows that the impulse was received and recognised by the electronics.

Attention: to use the TEST-button on a factory preset operator, it first must be set into LEARNING-Mode (indicated by the operator's blinking light). Otherwise the operator will only run for a short distance and stop with an error-message.

The TEST-button will work properly, once the operator was set up and the learning-cycle was completed.

LEARN-Button (2)

This button fulfills the following functions:

1. Learning the forces
2. Registering (learning) a hand-transmitter
3. Adjusting the length of the CLOSING Soft-Stop
4. Starting advanced programming functions

The LEARN-button must be pressed for approx. 3 sec.; the button can be released once the operator's light starts blinking. Whilst the operator's light is blinking you can either register a new hand-transmitter by pushing the hand transmitters button O R you may start the learning of forces by pressing the button once again. Details on both procedures can be obtained from the chapters "Programming Running-Length and Force" on page 13 and "Remote Control" on page 18.

Combined TEST + LERN button functions

Through a combined use of TEST and LERN button the following special functions can be adjusted:

1. Pre warning light
2. Duration of the internal light

How to adjust these functions is explained on page 14 "Special Functions".

Programming Running-Length and Force

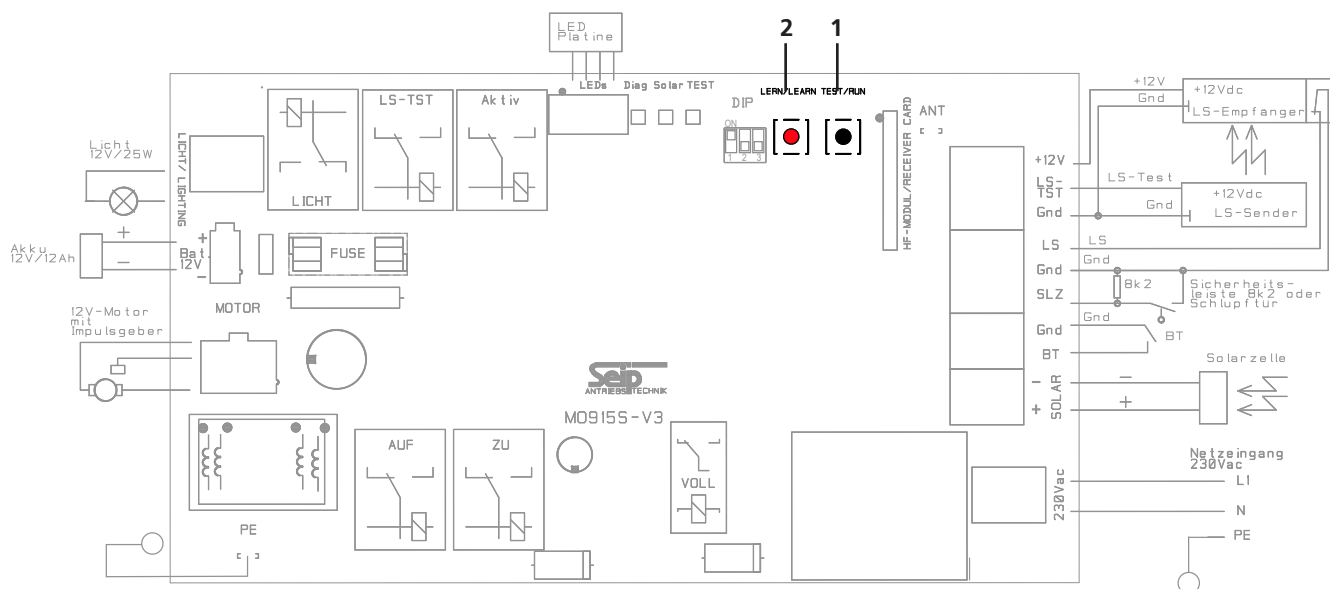

Information

To properly use the operator it is necessary to programme the running-length and the force. **Using the operator without these important adjustments may lead to damages on the garage door and the operator. For test-runs without a garage door the running-length blocks must be tightened (please refer to page 8 "Adjusting the running-length blocks").**

The programming procedure is done completely automatic with an automated procedure. The programming-mode needs to be started first - it will be indicated by the blinking operators' light.

The quick-reference on this page shows a short summary of the procedure.

1.) Adjusting the running-length blocks

This step is described on page 8, "Adjusting the running-length blocks". (Remark: the blocks are fixed by tightening the screw).

2.) Starting the programming-mode

Keep the LERN/LEARN button (2) pressed for 3 seconds - release it once the operators' light begins blinking. The operator is now running in programming-mode.

3.) Start the learning-cycle

Shortly press the LERN/LEARN button (2) once again. The operator now starts three fully automatic measurement-runs:

- 3.1. First the block for OPENING direction is searched for
- 3.2. Second the operator closes the garage door with low speed (during this run you may also change the length of the factory pre-set soft-stop, as described on page 13).
- 3.3. The operator stops when the garage door ist closed - the measured running-length is now stored in the memory
- 3.4. The operator opens the garage door and measures the required opening-force
- 3.5. The operator closes the garage door and measures the required closing-force
- 3.6. The operator stops in closing position and remains blinking for a couple of seconds.

Once all the measures values have saved in the memory the operators' light stops blinking - now the operator is ready for use.

Procede with the programming of hand-transmitters on page 18.

Quick Reference

1.) Adjustment of blocks

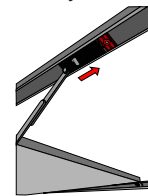

The running-length blocks for opening and closing direction must be properly adjusted (please refer to page 8)

2.) Start programming mode

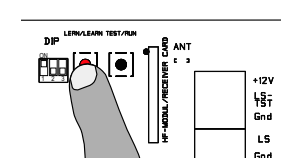

Press the LERN/LEARN button for approx. 3 seconds. The operators' light begins blinking - release the LERN/LEARN button

3.) Start the learning-cycle

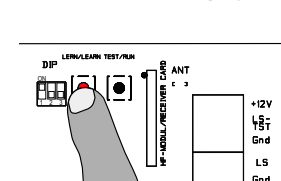

Press the LERN/LEARN button once again shortly: the operator now starts three fully automatic measurement-runs.

The learning cycle stops after the three runs. The garage door is then closed and the operators' light stops blinking. The programming is now complete.

4.) You may now procede with chapter "Remote Control" on page 18

INFORMATION:

When the learning-cycles are made as to the procedure described on this page, then the operator will be programmed with the standard values for the soft-modes. Shall the soft-modes be changed or disabled, then please refer to pages 14+15.

The learning-cycle can be repeated at any time. Running a new learning-cycle will overwrite the old values and substitute them with the new ones.

Special Functions

Readjusting the time for the internal light

The time for the internal light may be adjusted from 10 seconds to 5 minutes. The factory setting is 3 minutes.

To readjust the time proceed as described below:

1. Keep the **LERN/LEARN** button pressed for **6 seconds**. Release the button once the **green LED „TEST/FUNK“** turns on.
2. **Shortly** press the **LERN/LEARN** button again.
3. The green LED „TEST/FUNK“ now starts **blinking at 1 second intervals** - each blinking increases the time by 10 seconds.
5. Once the required time is reached, press again the LERN/LEARN button shortly. The value is then saved in the memory - the programming is finished.

LED TEST/FUNK blinks times	Time for light is:
6 x	1 minute
12 x	2 minutes
18 x	3 minutes
24 x	4 minutes
30 x	5 minutes

Setting the pre-warning ON/OFF

1. Keep the **LERN/LEARN** button pressed for **6 seconds**. Release the button once the **green LED „TEST/FUNK“** turns on.
2. **Shortly** press the **TEST/RUN** button
3. The **green LED TEST/FUNK** indicates whether the pre-warning is switched ON or OFF:
LED TEST/FUNK is off: pre-warning is OFF
LED TEST/FUNK is glowing: pre-warning is ON
4. by **shortly pressing** the **TEST/RUN** button the pre-warning can be switched ON and OFF
5. after making your choice shortly **press** the **LERN/LEARN** button - the setting will be saved to the operators' memory.

Quick Reference „Time for internal light“	
1.) Keep the red LERN button pressed for 6 seconds 	After 3 seconds the operators' light starts blinking, after 6 seconds the green LED „TEST“ turns on
2.) Release LERN button 	LED „TEST“ is on
3.) Shortly press LERN/LEARN button 	LED „TEST“ begins blinking at 1 second intervals. Each blinking adds 10 seconds to the time (starting from zero)
4.) Press LERN button shortly when required time is reached 	The adjusted time will be saved in the memory.

Quick Reference „Pre-Warning“	
1.) Keep the red LERN button pressed for 6 seconds 	After 3 seconds the operators' light starts blinking, after 6 seconds the green LED „TEST“ turns on
2.) Release LERN button 	LED „TEST“ is on
3.) Shortly press the black TEST button 	LED „TEST“ indicates status: LED on: pre-warning ON LED off: pre-warning OFF
4.) Shortly press the TEST button 	By pressing the TEST button the pre-warning is switched on and off: LED on: pre-warning ON LED off: pre-warning OFF
5.) Shortly press the red LERN button 	The chosen adjustment is saved into the memory.

Special Functions

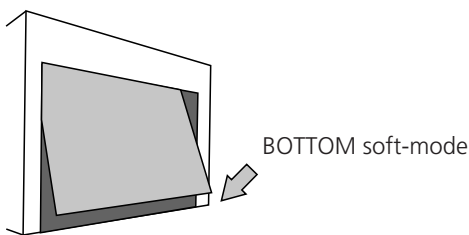

Quick Reference „Programming the BOTTOM Soft-Mode“

<p>1.) During the first learning cycle in CLOSING direction</p>	<p>Keep the LEARN button pressed during the first run in CLOSING direction and <u>keep it pressed</u> -the operator increases speed</p>
<p>2.) The operator is running in CLOSING direction with increased speed</p>	<p>Release the LEARN button at the position where the soft-stop shall start in future. <i>If the LEARN button is kept pressed until the door is completely shut, then the soft-stop will be disabled.</i></p>
<p>3.) The operator reaches the CLOSED position. It will proceed with the learning-cycle (two more runs) before finishing the programming. The CLOSING Soft-Stop will then be set as to your adjustments.</p>	

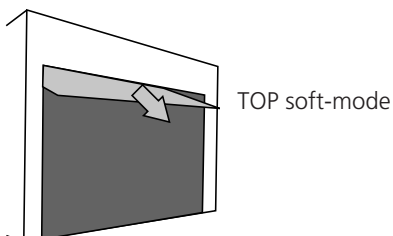

Quick Reference „Disabling the TOP Soft-Mode“

<p>1.) Set DIP-Switch No. 1 to OFF before starting the learning cycle</p>	
<p>2.) Start the learning cycle</p>	
<p>3.) Set DIP-Switch No. 1 back to ON when the learning cycle is completed</p>	

Programming the Soft-Modes

The TS Solar/TS Akku is shipped with factory pre-set values for the Soft-Modes; if the learning cycle is run without any changes to the factory-settings, then the pre-set values will be programmed automatically.

The BOTTOM Soft-Stop

The length of the BOTTOM Soft-Stop may be changed during the first run of the learning-cycle in closing direction.

- **Extending** the BOTTOM Soft-Stop is recommended, if the garage door slams on closing.

- **Reducing or disabling** the BOTTOM Soft-Stop is recommended, when the bottom of the garage door does not close completely. Especially when mechanical spring-locks are installed, these might not engage. When the BOTTOM Soft-Stop is disabled, the garage door reaches the closing position with a higher speed. This gives the door a higher momentum and the bottom can fall into the doors' frame - the locks can then engage.

Programming the BOTTOM Soft-Mode

The length of the soft-stop can be adjusted during the first automatic measurement-run in closing direction. Please proceed as described below:

1. Start the learning cycle (refer to page 11)
 2. the operator runs in closing direction with low speed
 3. press the LERN/LEARN button and keep it pressed - the operator is now increasing the speed
 4. release the LERN/LEARN button at the position where the soft-stop shall begin (*the operator will save this position as the beginning of the BOTTOM soft-stop*)
- If the Soft-Stop is to be disabled, then the LEARN button must be pressed until the door is completely closed.
5. the operator will reduce speed with a short delay and then reach the closing position
 6. the operator will proceed with the remaining measurement-runs

When the operators' light stops blinking, all measured values are saved in the memory - the BOTTOM soft-stop now is in the programmed position.

Disabling the TOP Soft-Modes

The TS Solar/TS Akku will start the closing procedure from OPENING position with slow speed (e.g. TOP Soft-Mode). Dependant on the performance of the garage door it might be necessary to disable this Soft-Mode, especially when the operator reverses during that period (e.g. pressure detection).

Procedure for disabling the TOP Soft-Mode

Set DIP-Switch no. 1 to OFF before starting the learning cycle and leave it in that setting until the learning cycles are completed - the TOP Soft-Mode then is disabled. After the learning cycles the DIP-switch no. 1 fulfills its' normal function („Normal Force/Higher Force during CLOSING Soft-Stop“ as to page 17).

TIP: should you decide to remove the jumper, then plug it back onto one pin only - so it remains available on the P.C.B. for later use.

External Connections

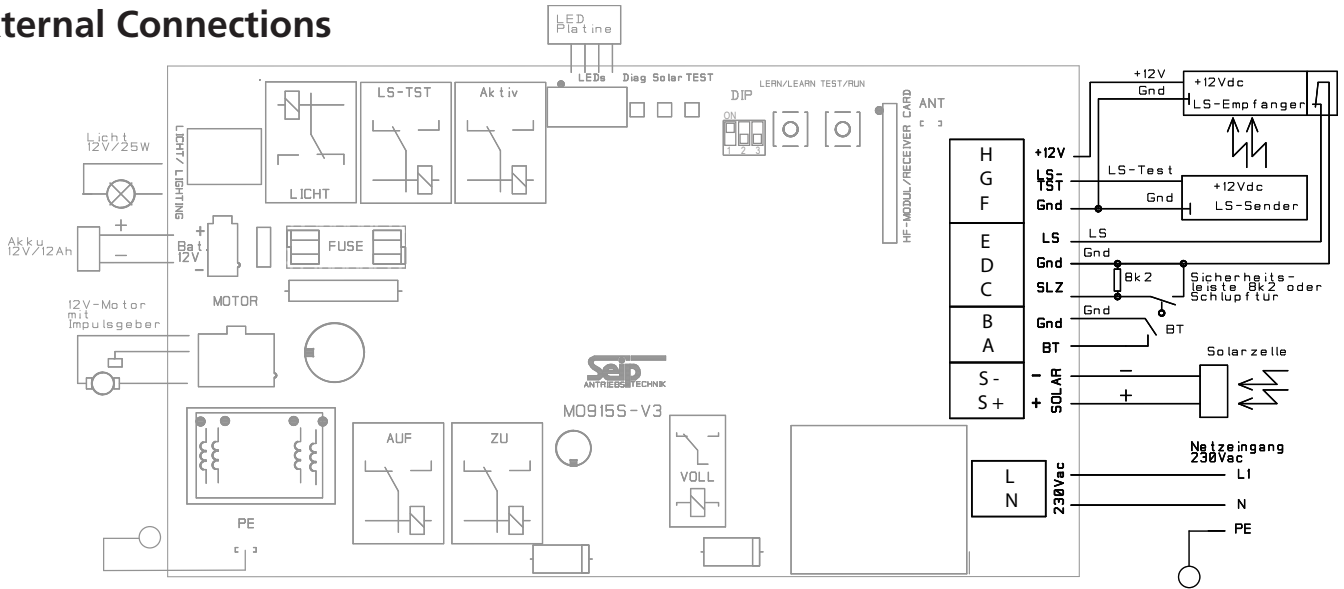

Connector	Function
Push Button and Key Switch BT + Gnd (A + B)	Floating connector for push button and key switch: no electricity to come into contact with these connectors!
12V DC Supply „+12V“ + Gnd (F + H)	12V DC Power Supply for external security devices, 150 mAmp. max. <i>This connector only carries voltage as long as the operators light is switched on; it can therefore not be used for external remote-receivers!</i>
Receiver-Module HF-Modul / Receiver-Card	Plug for a Seip receiver module

Advanced Connections

Component	
Photocell without self-test N.C.	Connection:
Photocell with self-test N.C.	Explanation: the P.C.B. offers the possibility to check the photo cells functions before the operator starts running. This test is made by simulating a fault on the photo-cell for 1 Second before every run. ATTENTION: if the self-testing function shall be used, then the photo cell must be connected as shown below <u>BEFORE running the learning-cycle</u> - otherwise the self-test will not work!

Advanced Connections

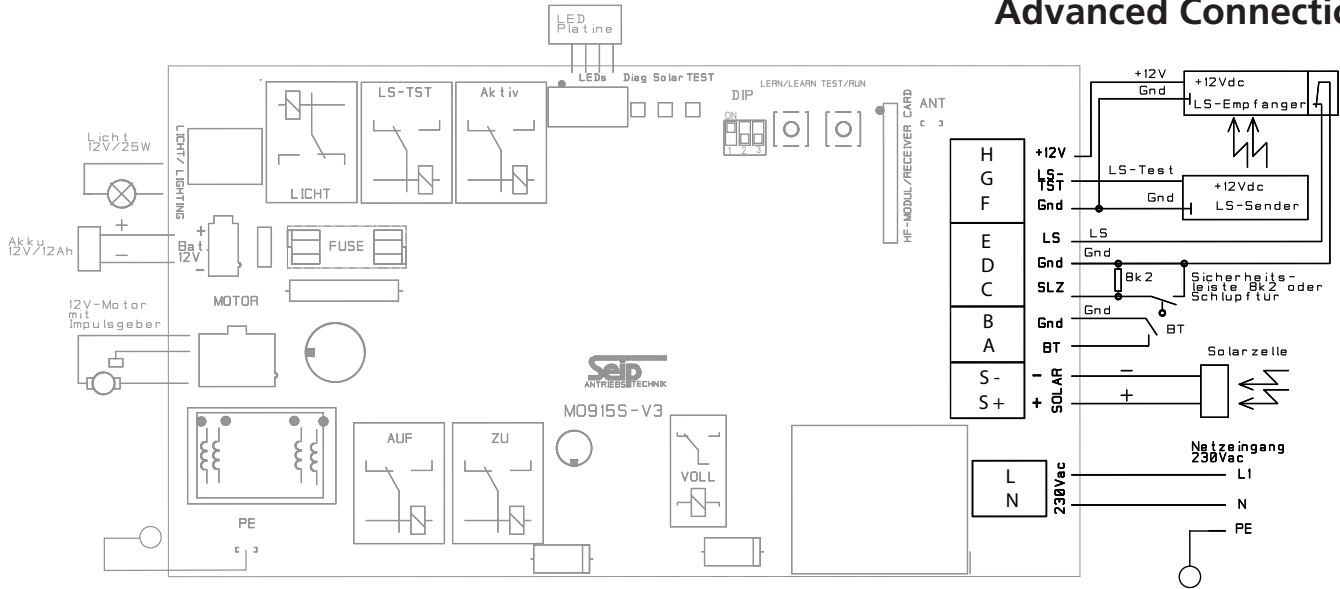

Safety-Beam, Hatch-Door and Emergency Stop

(N.O.)
(with 8,2 kOhm resistor)

Function

The devices on this connector are checked during the complete opening and closing procedure. When this connector is interrupted, then the operator will stop immediately followed by a short reversion. **If more than one device is connected, then they must be connected in series.** The connector can be used for the following components:

1.) Safety-Beam

Standard safety-beams are equipped with an 8,2kOhm resistor. The resistor on the P.C.B. (between „Gnd“ and „SLZ“) must therefore be removed.

2.) Hatch-Door Contact

A hatch-door within the garage door can be secured with a switch - when the switch is not activated (e.g. the hatch-door stands open) the operator will not work.

3.) Emergency Stop

The procedure to connect an emergency stop push-button is the same as for the hatch-door contact.

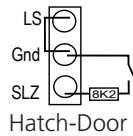
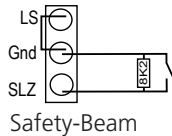

Opto Sensoric Components

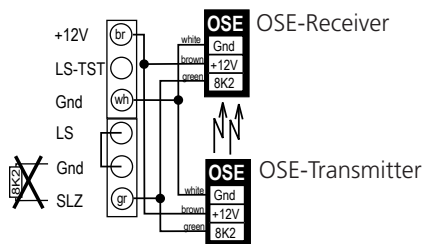



DIP-Switches

DIP-Switch No.	Function	ON	OFF
1 (Two Functions!)	<i>Standard setting: ON</i> Function 1: (DIP-Switch position before and during the learning cycle) TOP Soft-Mode enabled/disabled (ref. page 15)	enabled	disabled
	Function 2 (DIP-Switch position after the learning cycle) Force during the last 500mm before reaching closing limit	normal force	higher force
2	<i>Standard setting: ON</i> Side Hinged Door	side hinged door	tilting or sectional door
3	no function	-	-



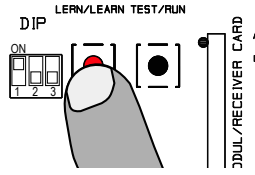
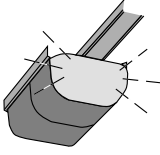

Programming the Hand Transmitters

Quick reference: programming the first hand transmitter

<p>1.) Keep the LERN/LEARN button pressed for approx. 3 sec.</p> 	<p>The operators' light will start blinking</p> 
<p>2.) Press the hand transmitter button you want to use</p> 	<p>The operators' light stops blinking - the transmitter was successfully programmed</p>

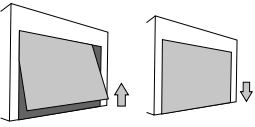
Quick reference: Programming additional hand transmitters from a distance

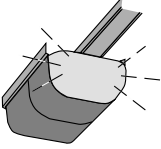
Remark: additional hand transmitters can be programmed either like the first transmitter or from a distance as explained below:

<p>1.) Open the garage door for approx. 50 cm and close it again</p> 	<p>After the garage door is closed you have got 10 seconds to proceed to step 2)</p>
<p>2.) Press buttons 1+2 simultaneously on any registered transmitter for 3 sec.</p> 	<p>The operators' begins blinking - release the hand transmitters' buttons</p> 
<p>3.) Take the new hand transmitter and press the button you want to use shortly</p> 	<p>The operators' light stops blinking - the hand transmitter was successfully programmed</p>

Basics

As a standard the operator is equipped with a 433 MHz AM remote control set. The coding is done via rolling code - the code is changed after each impulse; receiver and transmitter agree completely automatic about the next code to be used. New codes will be chosen out of a pool of billions of possible codes.

Your operator is equipped with our standard remote control set when you hand transmitters looks like the one shown on the right hand side. The 4-channel MIDI transmitter is standard equipment, the 2-channel MINI transmitter is available as an optional.

If your operator is equipped with another remote control set, please refer to the manufacturers instructions for programming.

Programming Transmitter and Receiver

To use a hand transmitter it must first be registered (programmed) by the receiver. Only one hand transmitter button can be used for one receiver.

Registering the first hand transmitter

The first hand transmitter (e.g. no hand transmitter has been registered for the receiver, yet) must be learned directly via the operators' main electronic:

1. Press the LERN/LEARN button on the main electronic for approx. 3 seconds until the operator's light starts blinking and release the LERN/LEARN button.
2. Press the hand transmitter button you want to register to the receiver - the operators' light stops blinking when the transmitters' signal was received. The transmitter is now registered.

Registering additional hand transmitters

When at least one hand transmitter has been registered by the receiver you may program additional hand transmitters from a distance:

1. The garage door must be closed
2. Open the garage door approx. 50 cm and close it again.
3. After the garage door is closed you have got 10 seconds to press the buttons 1+2 simultaneously on the registered hand transmitter - the operator's light then starts blinking.
4. The light will keep blinking for another 10 seconds - during that period of time you must press the button on the new hand transmitter which you want to use with the operator. Once the new transmitter is registered the operator's light stops blinking.

The procedure must be repeated for each new hand transmitter.

Clearing the receivers' memory

Keep the LERN/LEARN button pressed for approx. 15 sec.. The operators' light and the red LED „Diag“ will start blinking after 3 seconds. After another 10 seconds the red LED „DIAG“ will glow constantly. You can then release the LERN/LEARN button.

All previously programmed hand transmitters are now cleared from the receivers' memory.

Additional Information

Using the remote-control

To reduce the power consumption the remote-receiver is being switched on and off in short intervals when the operator is in stand-by mode.



Therefore the hand transmitters button must be kept pressed for approx. 3 seconds to make sure, that the signal is recognized by the receiver.

As long as the operators lighting is switched on, the receiver is activated permanently. During this time even shorter signals from the hand transmitter are recognizes immediately.

Criteria influencing the range

The TS operators are equipped with a high quality remote control set as a standard!

Nevertheless the remote control is the part of the operator which might be influenced by circumstances in the surroundings of the garage. With our standard remote control you might reach a range of more than 100 meters. In areas with high disturbances the range will still be approx. 50 meters.

The range might be influenced by:

- old batteries in the hand transmitter - if you should experience a problem with the range, please change the batteries first. The lower the batteries run the lower the range will be.

- Building materials of the garage

In a garage made of concrete and steel you might reach a lower range than in an ordinary garage build of stone. The more steel was used for the walls the shorter the range of your remote-control.

- Remote-control activity in the area

- Radio and television transmitters close to your garage might reduce the range.

- Older baby-phones

Especially older baby-phones might influence the range of the remote control severely. These devices send strong signals via the houses internal power supply net. These signals also intrude other devices via the wall plug, as eg the operator.

It is extremely unlikely that the range will drop to an unacceptable distance. If, however, problems should occur we will like to be helpful.

Use with a HomeLink® System

The HomeLink® System is becoming more and more popular in private households. Most frequently it is being used in cars - the HomeLink® module is integrated in the car. It allows the driver to activate the door operator with a push of button which is installed in his car. Once programmed, the driver does not need the hand transmitter to access the garage with his car.

The standard remote control supplied with the TS-series is compatible with HomeLink® systems from **Software Revision 6** or higher. Older Software Revisions are not supported. Information on the Software Revision in your car can be obtained from the cars documentations.

Information on how to program your HomeLink® device can either be obtained from your cars documentations or from the internet site www.eurohomelink.com.

4-channel MIDI transmitter,
433 MHz, rolling code

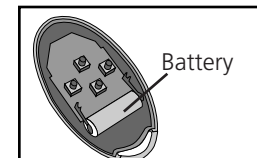
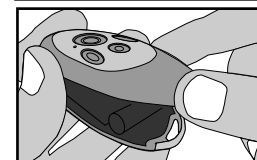
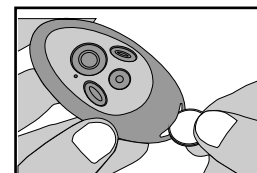
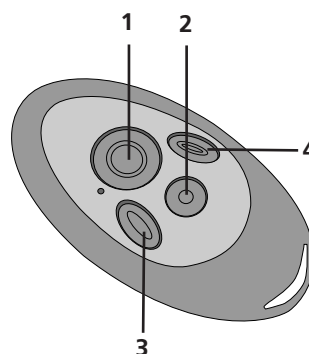

Usable types of batteries: A23, 23A, 23L, EL12, VR 22 and MN 21

Voltage: 12V

Used batteries must be disposed of according to national laws!

2-channel MINI transmitter (optional extra),
433 MHz, rolling code

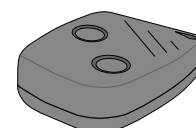

Two Batteries

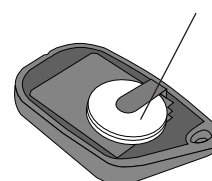

Two batteries, type CR1616 or DL1616 are required.

Voltage: 2* 3V (=6V)

Used batteries must be disposed of according to national laws!

Please avoid to drop the hand transmitter - parts could be damaged inside the transmitter. That might lead to malfunctions!

Technical Data

Maximum Pulling Force	55 kg (+/- 4%)
Force-Setting for Operation	automatic
Motor	12V DC, low-noise
Running Speed	14 cm/sec.
Speed in Soft Mode	8 cm/sec.
Lighting	12Vdc, max. 15 watts
Lighting Durance (adjustable)	10 to 300 seconds
Duty Cycle	80%
Accumulator	2 units, Lead, 12V, 12Ah, Type Panasonic LC-RA1212P
Expected Accumulator Life-Time	3 to 5 years approx.
Power Supply TS Akku II	Lead-Accumulator, 12V, 12Ah, Type Panasonic LC-RA1212P

Pre-Warning Light	adjustable
Soft-Stop in Closing Direction	adjustable
Net Running Length	2.640 mm
Max. Running Length with Extension (500 mm)	4.050 mm
Overall Length	3.200 mm
Height Motor Head	180 mm
Length Motor Head	360 mm
Width Motor Head	180 mm
Minimum Space above the door	35 mm
Noise-Emission	≤ 60 dB(A)

Used batteries require a special waste management
Used batteries must be disposed according to national laws!

Wiring

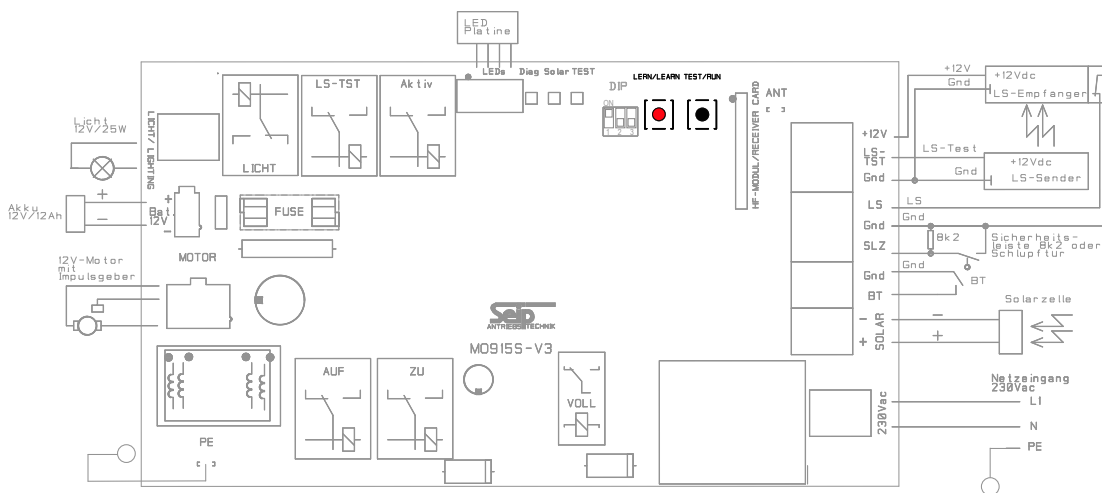

Internal Wiring	
230Vac	Blue, mains supply, 230V (N) Brown, mains supply, 230V (L1)
Licht/ Lighting	Brown+blue, Lighting, 12V
Bat 12V	Plug for Battery-Cables (red cable (+)-Pole, black cable (-)-Pole)
MOTOR	Connector for the plug from the motor
PE	Earthing from the printed circuit board to the base plate
Earth Cable from power cord	The earthing of the mains supply (green/ yellow) is connected to the base plate with a screw
SOLAR	Solar Panel, brown (+) and blue (-) <i>TS Solar only</i>

Devices for adjustments	
Button „Test/Run“	Runs the operator - OPEN-STOP-CLOSE
Button „Lern/Learn“	For automatic force setting and registration of hand transmitters
Others	
HF-Modul/Receiver Card	Plug for receiver module, 433 MHz
FUSE	Fuse T10A

Messages from LED-lamps and operators lighting

The TS Solar/TS Akku is equipped with an automatic diagnostic system which provides information via the external LED-lamps. These messages are:

Status Messages

In intervals of 10 seconds the yellow and green LED-lamps give information about the battery status and if the battery is being recharged or not.

Yellow LED (Recharging of the battery)	
0 blinks	The battery is not being recharged. TS Solar I: no energy from the solar panel (e.g. at night) TS Akku I: no 230V power supply
1 blink	The battery is being recharged TS Solar I: energy is received from the solar panel TS Akku I: 230V are coming from the net
Green LED (Status of the battery)	
0 blinks	The battery has no sufficient voltage to run the operator - the electronic disables the operator until the battery was recharged. It will then automatically enable the operator.
1 blink	The batteries voltage is low, the operator can only be used for a restricted number of runs. When this state is reached, the operators light will be blinking during the run.
2 or 3 blinks	The battery is full and provides sufficient voltage to run the operator.

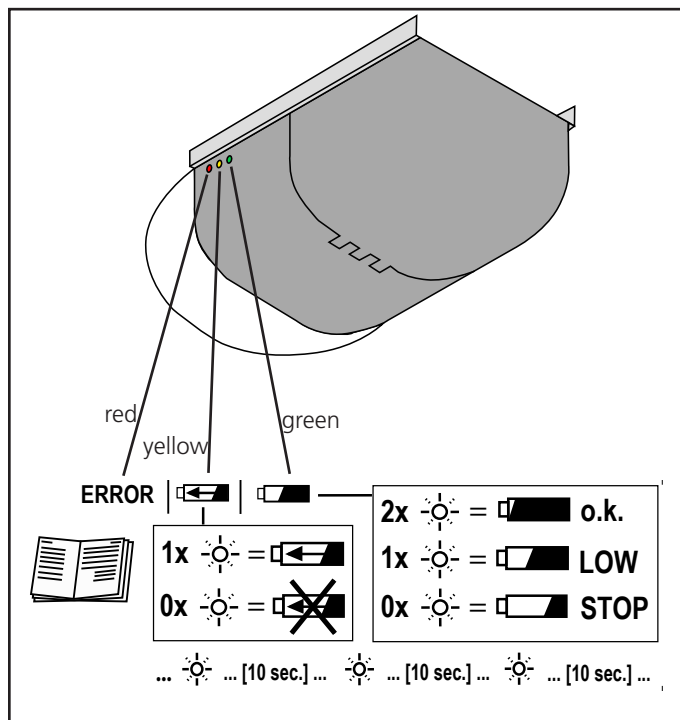

Error Messages

Error Messages are provided by the red LED lamp „Diag“ on the electronics together with the red LED lamp on the outside of the housing. With some of the messages the operators lighting will be blinking simultaneously.

Messages from the red LED-lamp and the operators lighting	
2 blinks	The limits cannot be reached though neither an obstacle was nor a damage on the hall-sensor was detected. There is eventually a damage on the operators' mechanics - the electronic disables the operator.
5 blinks	The microprocessor has lost its data; try to execute the learning cycle. If this does not work, then the electronics needs to be exchanged.
6 blinks	No information can be written to the microprocessor. The electronics disables itself and needs to be exchanged.
7 blinks	A relais is damaged - The electronics disables itself and needs to be exchanged.
8 blinks	General fault. The electronics disables itself and needs to be exchanged.
9 blinks	Error with the detection of Hall Sensor signals. Either the motors' Hall Sensor or the electronics is faulty.

Additional Messages only from the red LED lamp	
3 blinks	Photo Cell - either an obstacle is blocking the photo cell or the photo cell is damaged. The error message will be cancelled, when the error was eliminated.
4 blinks	Error on the 8k2 connector (Safety Beam/Hatch Door) - ei Fehler an der 8k2-Auswertung (Schlupftür/Kontaktleiste) - either an obstacle is blocking the Safety Beam/Hatch Door or one of the devices is faulty. The error message will be cancelled, when the error was eliminated.

EC Declaration of Conformity
 Low-Voltage Directive 73/23/EEC
 and amendments
 Electro-Magnetical Compatibility 89/336/EEC
 and amendments

Document No. AN-16062003
 Dokument Nr. AN-16062003



EG-Konformitätserklärung
 im Sinne der EG-Richtlinien
 Niederspannungsrichtlinie 73/23/EWG
 mit Änderungen
 Elektromagnetische Verträglichkeit 89/336/EWG
 mit Änderungen

We,
 Wir,

Seip Antriebstechnik GmbH
Grombacher Straße 83, 75045 Walzbachtal-Jöhlingen, Deutschland

hereby declare, that the following products comply to the mentioned EC-regulations.
*erklären hiermit, daß die nachfolgenden genannten Produkte den unten angegebenen
 EG-Richtlinien entsprechen.*

Type of Product / Produktart	Garage Door Operator / Torantrieb
Product Name / Modell	TS Solar/TS Akku
Approved according to 89/336/EEC and 73/23/EEC / Geprüft nach 89/336/EWG und 73/23/EWG	
Referring EC-regulations: / Angewandte harmonisierte Normen:	
Electromagnetic Compatibility / Elektromagnetische Verträglichkeit	EN 61000-3-2:2000 Limits for harmonic current emissions / <i>Grenzwerte für Oberschwingströme</i> EN 61000-3-3:1995 + Corrigendum:1997 + A1:2001 Limitation of voltage changes, voltage fluctuations and flicker in publik low-voltage supply systems / <i>Grenzwerte für Spannungsschwankungen und Flicker</i> EN 61000-6-3:2001 Emission standard for residential, commercial and light-industrial environments / <i>Störaussendung für Wohnbereich, Geschäfts- und Gewerbebereiche sowie Kleinbetriebe</i> EN 61000-6-2:2001 Generic standards - Immunity for industrial environments <i>Fachgrundnorm - Störfestigkeit - Industriebereich</i>
Low-Voltage Directive / Niederspannungsrichtlinie	EN 60335-2-95:2001-7 Particular requirements for drives for vertically moving garage doors for residential use / <i>Anforderungen für Antriebe von Garagentoren mit Senkrechtbewegung zur Verwendung im Wohnbereich</i> EN 60335-1:1994 + A1:1996 + A2:2000 + A11:1995 + A12:1996 + A13:1998 + A14:1998 + A15:2000 + A16:2001 Safety of household and similar electrical appliances / <i>Sicherheit elektrischer Geräte für den Hausgebrauch</i>
Safety in Use / Nutzungssicherheit	EN 12453:2000 Safety in use of power operated doors, requirements / <i>Nutzungssicherheit kraftbetätigter Tore, Anforderungen</i> EN 12445:2000 Safety in use of power operated doors, Test methods / <i>Nutzungssicherheit kraftbetätigter Tore, Prüfverfahren</i>

Peter Seip, Geschäftsführer, Walzbachtal-Jöhlingen, 24.01.2005



Grombacher Straße 83
 75045 Walzbachtal-Jöhlingen
 Germany
 www.seip.com

EC Declaration of Conformity
in accordance with the Radio and Telecommunications
Terminal Equipment Act (FTEG) and Directive 1999/5/EC
(R&TTE Directive)

EG-Konformitätserklärung
gemäß dem Gesetz über Funkanlagen und Telekomm
unikationsendeinrichtungen (FTEG) und der Richtlinie
1999/5/EG (R&TTE)

Document No. FU-18102004
Dokument Nr. FU-16062003



We,
Wir,

Seip Antriebstechnik GmbH
Grombacher Straße 83, 75045 Walzbachtal-Jöhlingen, Deutschland

declare that the product
erklären, daß das Produkt

SKR 433-1

Code B43A023004-1

Hand Transmitter as remote control for garage door operators
Handsender als Fernbedienung für Garagentorantriebe
(Short Range Device)
(Funkgerät geringer Reichweite (SRD))

complies with the essential requirements of §3 and the other relevant provisions of the FTEG (Article 3 of the R&TTE Directive), when used for its intended purpose.
bei bestimmungsgemäßer Verwendung den grundlegenden Anforderungen des §3 und den übrigen einschlägigen Bestimmungen des FTEG (Artikel 3 der R&TTE) entspricht.

§3(1)1, (Article 3(1)a) does not refer to this type of product.
§3(1)1, Artikel 3(1)a bezieht sich nicht auf diesen Produkttyp, es gibt hierzu keine Norm

Protection requirement concerning electromagnetic compatibility §3(1)(2), (Article 3(1)(b))
Schutzanforderungen in Bezug auf die elektromagnetische Verträglichkeit §3(1)2, Artikel 3(1)b)

EN 300 220-1/1997
EN 300 683/1997
EMV / EMC Directive 89/336/EEC;92/31/EEC;93/68/EEC

Peter Seip, Geschäftsführer, Walzbachtal-Jöhlingen, 16.06.2003

Seip GmbH
ANTRIEBS | TECHNIK

Grombacher Straße 83
75045 Walzbachtal-Jöhlingen
Germany
www.seip.com

